

Reinhold Environmental Ltd.

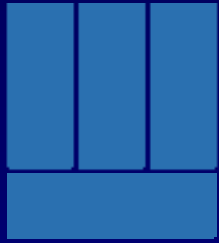

2009 NOx-Combustion Round
Table & Expo Presentation

February 9 & 10, 2009, Cleveland, OH



WAHLCO, Inc.

Economics of Ammonia vs. Urea

2009 NO_x Roundtable

February 9, 2009

NO_x Reduction Requirements

- SCRs Required all New Fossil Units
- Increasing regulations for Industrial Applications
- NO_x Credits Currently High ~ \$1500 ton
- Many SCR's Retrofits Required
- Further Reductions in NO_x Emissions are Expected to Continue

DeNO_x Reagents

- SNCR's boiler temperatures influence selection
 - Direct Urea Injection Most Common
 - Some systems use aqueous or anhydrous ammonia
- SCR Technology
 - Anhydrous Ammonia
 - Aqueous Ammonia
 - Urea to Ammonia



WAHLCO[®]

Copyright 2008, Wahlco, Inc.

U₂A[®]

www.wahlco.com

714-979-7300

Feed Stock Cost Issues

- Equipment Capital Costs
 - Installed Cost
- Operating Costs
 - Feedstock
 - Energy
 - Manpower Requirements
- Permitting and Safety Related Issues
 - Ongoing Safety Training
 - Hazardous Materials Compliance



WAHLCO[®]

Copyright 2008, Wahlco, Inc.

U2A[®]

www.wahlco.com

714-979-7300

Economic Evaluation

Item	Anhydrous	29.4% Aqueous	19.7% Aqueous	Urea
500 MW Single Unit	500	500	500	500
Capital Cost	\$ 3,852,600.00	\$ 2,672,600.00	\$ 2,797,000.00	\$ 4,835,300.00
Levelized Annual Cost	\$ 1,783,555.00	\$ 2,636,197.00	\$ 3,317,235.00	\$ 2,904,950.00
Levelized \$/%Ton Equivalent NH3	\$ 452.00	\$ 669.00	\$ 842.00	\$ 737.00

Item	Anhydrous	29.4% Aqueous	19.7% Aqueous	Urea
2 x 600 MW Units	1200	1200	1200	1200
Capital Cost	\$ 6,058,200.00	\$ 4,863,800.00	\$ 5,100,300.00	\$ 6,621,390.00
Levelized Annual Cost	\$ 3,870,845.00	\$ 6,194,718.00	\$ 7,627,580.00	\$ 5,594,533.00
Levelized \$/%Ton Equivalent NH3	\$ 409.00	\$ 655.00	\$ 806.00	\$ 591.00

Item	Anhydrous	29.4% Aqueous	19.7% Aqueous	Urea
4 x 800 MW Units	3200	3200	3200	3200
Capital Cost	\$ 9,674,700.00	\$ 8,781,300.00	\$ 9,602,900.00	\$11,705,200.00
Levelized Annual Cost	\$ 9,055,543.00	\$15,694,608.00	\$ 19,562,870.00	\$12,728,518.00
Levelized \$/%Ton Equivalent NH3	\$ 359.00	\$ 622.00	\$ 775.00	\$ 505.00

*Data from "Optimization of Ammonia Source for SCR Applications", Paper by Reda Salib and Robert Keeth, Washington Group International, Denver

3 Different Ammonia Feed Stocks



WAHLCO®

Copyright 2008, Wahlco, Inc.

U₂A®

www.wahlco.com

714-979-7300

Feed Stock Reagents

- Urea (Dry and Liquid)
- Aqueous Ammonia
- Anhydrous Ammonia



WAHLCO[®]

Copyright 2008, Wahlco, Inc.

U₂A[®]

www.wahlco.com

714-979-7300

Feed Stock Anhydrous Ammonia

- Anhydrous
 - Presently the Lowest Capital and Operating Costs
 - Highest Risk
 - Greatest Permitting Issues
 - On Going Safety Training Costs
 - Greatest Uncertainty with Future Regulatory Issues
 - Increasing Transportation Costs

Feed Stock Aqueous Ammonia

- Aqueous
 - Much Higher Capital and Operating Costs
 - Less Risk than Anhydrous
 - Huge Storage Volumes and Handling Costs
 - Regulated Toxic Chemical
 - Permitting Issues
 - On Going Safety Training Costs
 - Some Uncertainty with Future Regulatory Issues
 - Increasing Transportation Costs

Feed Stock Urea

- Urea
 - The Highest Capital Costs
 - Generally Lower Operating Costs than Aqueous Ammonia
 - Lowest Risk
 - No Permitting Issues
 - No Uncertainty with Future Regulatory Issues



WAHLCO[®]

Copyright 2008, Wahlco, Inc.

U₂A[®]

www.wahlco.com

714-979-7300

Properties of Ammonia Feed stocks

- Urea
 - Supplied Dry
 - 70% Solution
 - Atmospheric Storage Tanks (API 650)
- Aqueous Ammonia
 - Concentrations from 19 to 29%
 - Above 19% requires pressure vessel
- Anhydrous Ammonia
 - Liquid when kept under pressure/temperature
 - Always requires pressure vessel

Anhydrous Ammonia



WAHLCO[®]

Copyright 2008, Wahlco, Inc.

U₂A[®]

www.wahlco.com

714-979-7300

Anhydrous Ammonia

- Anhydrous = Very little water (0.2-0.5%)
- Pungent, colorless gas
- Stored as liquid under pressure
(or refrigerated)
- Flammable compressed gas
- Pressure varies greatly with temperature
 - e.g. 50° F \approx 72 psi ; 90° F \approx 160 psi



WAHLCO[®]

Copyright 2008, Wahlco, Inc.

U₂A[®]

www.wahlco.com

714-979-7300

Anhydrous Properties

- Density @ 60 deg F ~ 38.5 lbs/ ft³
- Explosive Limits 16 to 25% in air
- Boiling point -28deg F
- Energy to Vaporize ~ 540 btu/ lb
- National Response Center Notification with 100 lb release
- Lethal Limit 5 minutes at 5000 ppm



WAHLCO[®]

Copyright 2008, Wahlco, Inc.

U₂A[®]

www.wahlco.com

714-979-7300

Anhydrous Ammonia

Vapor Pressure vs. Temperature

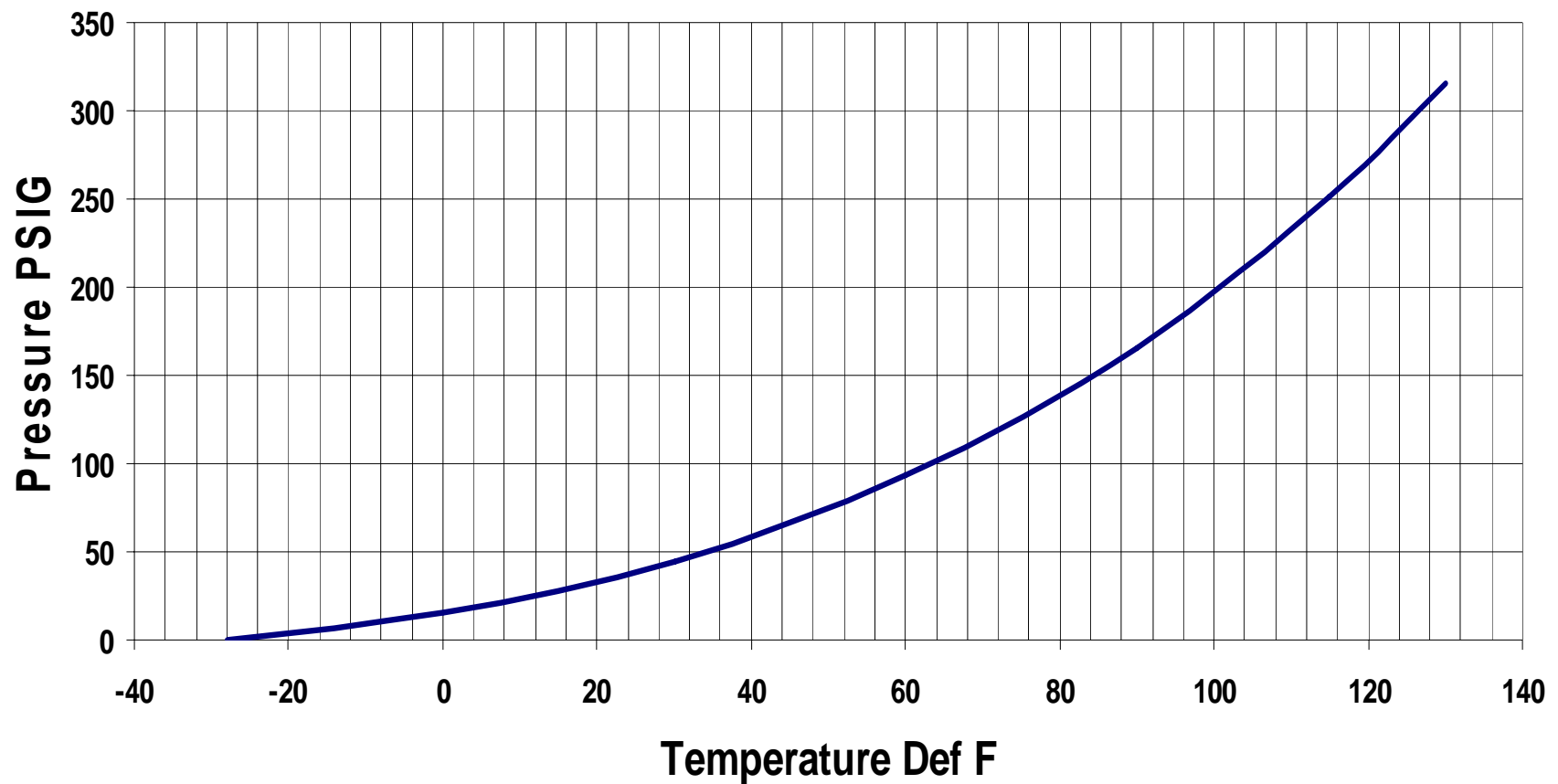

Anhydrous Ammonia Flow Diagram

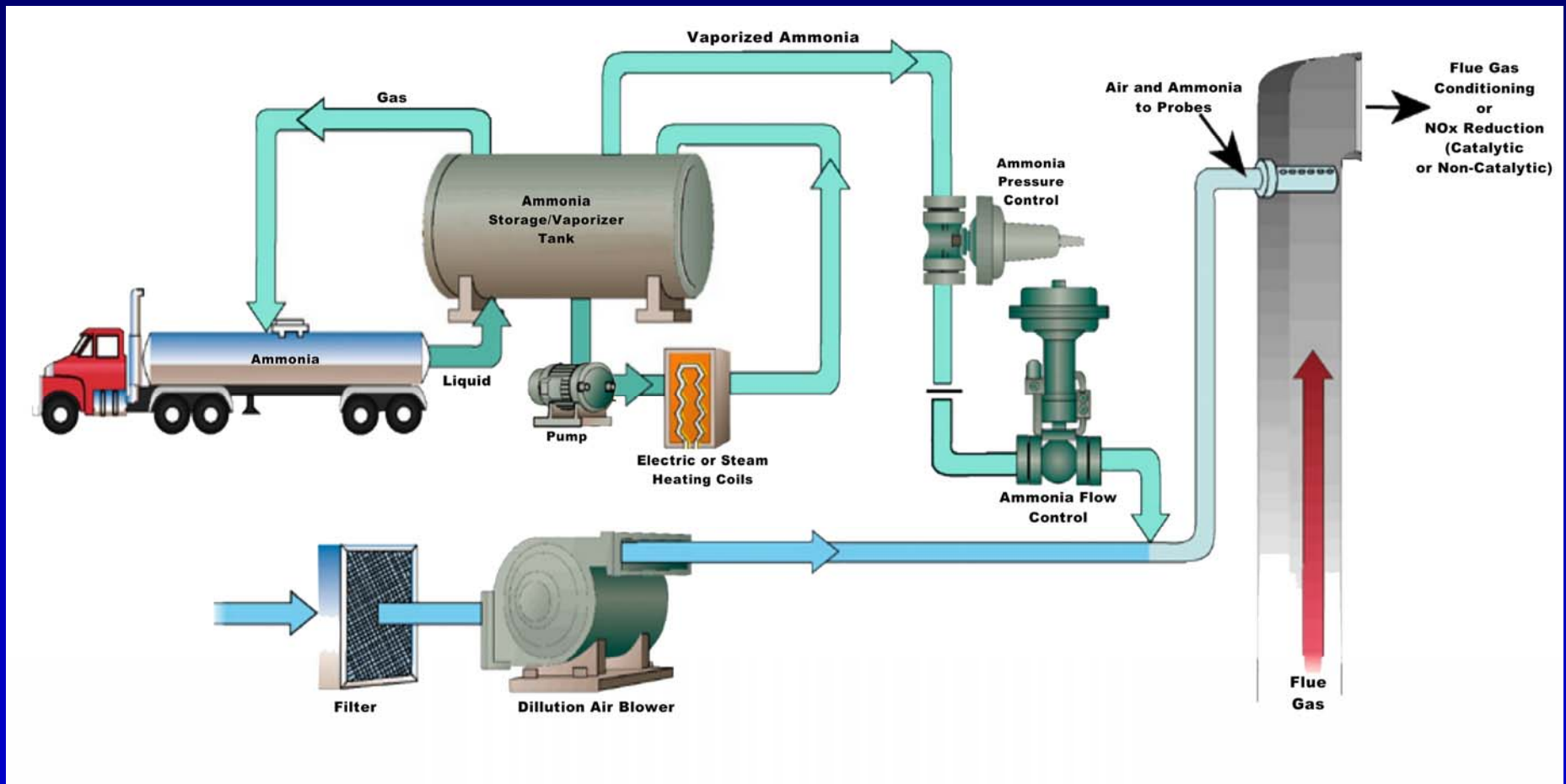

Anhydrous Ammonia Safety Issues

- Anhydrous Ammonia highly toxic lethal chemical
- Almost 10,000 accidental releases in ten years
- Storage entails high liability
- Regulated by Homeland Security
- Requires Coded Pressure Vessels
- Transportation costs rapidly increasing due to Liability issues – can not be trucked in many areas



WAHLCO[®]

Copyright 2008, Wahlco, Inc.

U₂A[®]

www.wahlco.com
714-979-7300 

Aqueous Ammonia



WAHLCO[®]

Copyright 2008, Wahlco, Inc.

U₂A[®]

www.wahlco.com

714-979-7300

Aqueous Ammonia

- Ammonium Hydroxide (NH_4OH)
- Various Concentrations
 - 29.4%, 25%, 19.5%, 11% others
 - At 29% Pressure Vessel Required
- Liquid
- Low pressure
 - at 100° F = 21.1 psi (29.4%)
- 7.3 lb/gal (29.4% solution)

Aqueous Ammonia 19%

- National Response Center Notification with 1000 lb release (190 lbs of ammonia)
- Required EPA risk management plan for >20% and 20,000 lbs
- Freezing point ~ -30 deg F
- Heat of Vaporization ~ 981 btu's/lb (5163 btu's / 1 lb NH₃)
- Must keep vaporized mixture above dewpoint to point of use



WAHLCO®

Copyright 2008, Wahlco, Inc.

U₂A®

www.wahlco.com

714-979-7300

Aqueous Ammonia

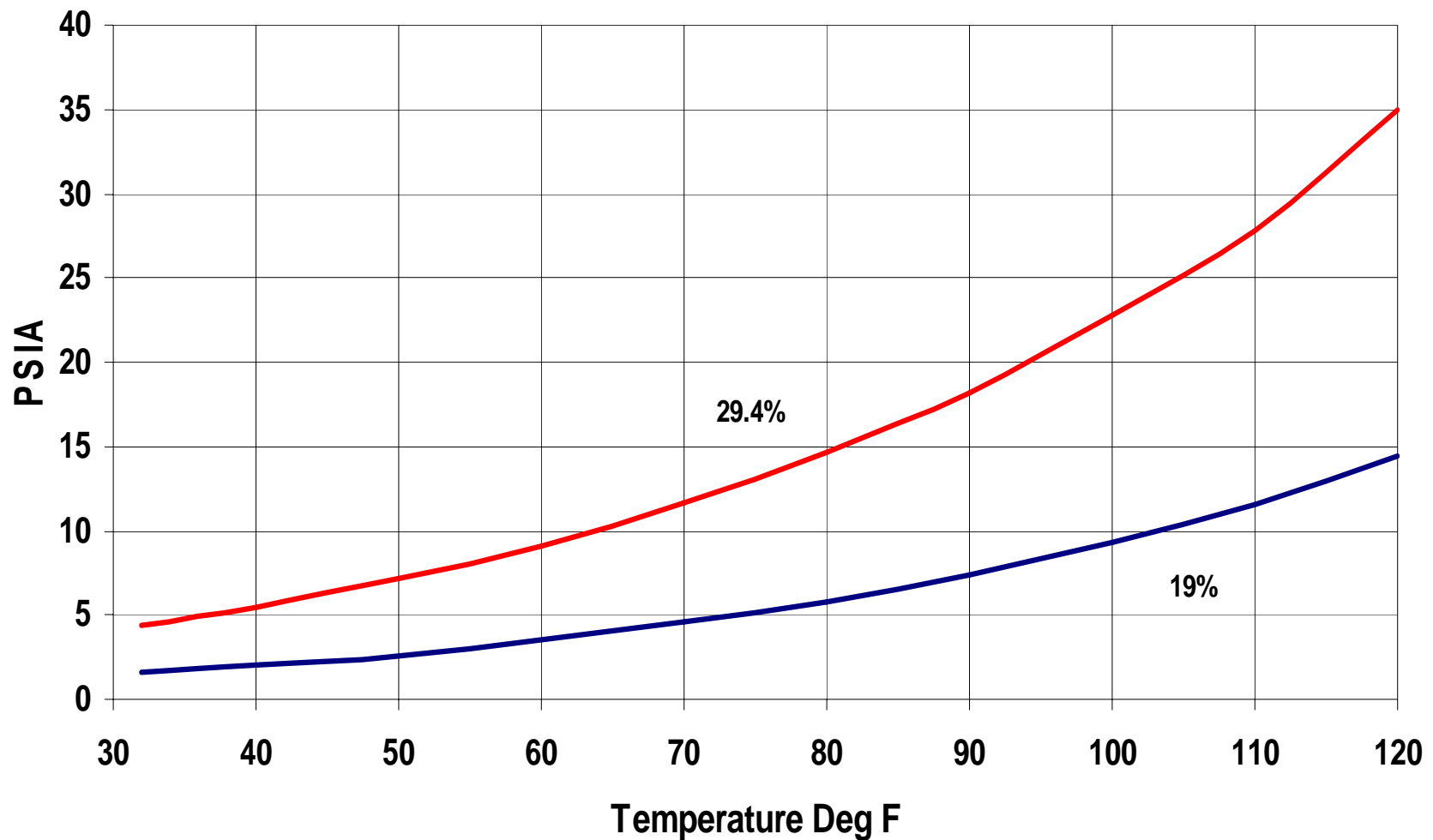

Aqueous Ammonia Block Diagram

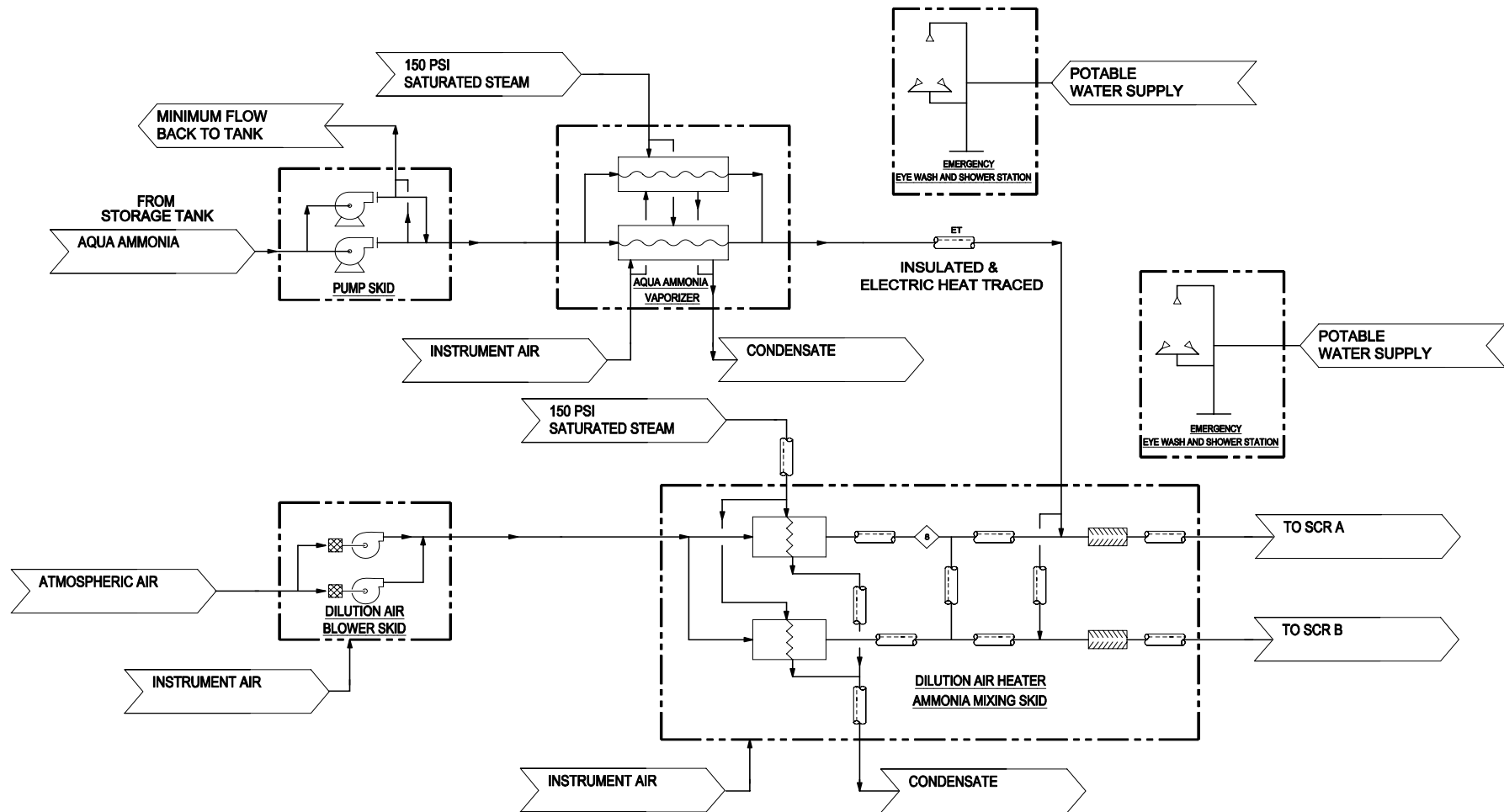

Aqueous Ammonia Safety Issues

- Regulated toxic chemical
- EPA RMP toxic release distances 1/3 to 1/2 of Anhydrous Ammonia
- Large Storage Volumes
- Increased Transportation Handling Risk



WAHLCO[®]

Copyright 2008, Wahlco, Inc.

U₂A[®]

www.wahlco.com

714-979-7300

Urea



WAHLCO[®]

Copyright 2008, Wahlco, Inc.

U2A[®]

www.wahlco.com

714-979-7300

U₂A[®] Technology

- Process Converts Urea to Ammonia on Site as it is needed by boiler load
- U₂A[®] (urea to ammonia): Reduces risks
- Eliminates the hazards from: shipping, handling, transfer or storage of ammonia
- Easier and less expensive to permit
- New Railroad Regulations will make Ammonia much more Expensive

Urea

- Urea (NH_2CONH_2)
 - Essentially harmless to the environment
 - Safely transported, stored and handled
- Readily available bulk commodity chemical
 - Used as fertilizer, in plastics, in adhesives and in pharmaceuticals
 - Available in solid form or as commercial solution



WAHLCO®

Copyright 2008, Wahlco, Inc.

U₂A®

www.wahlco.com

714-979-7300

Urea Production

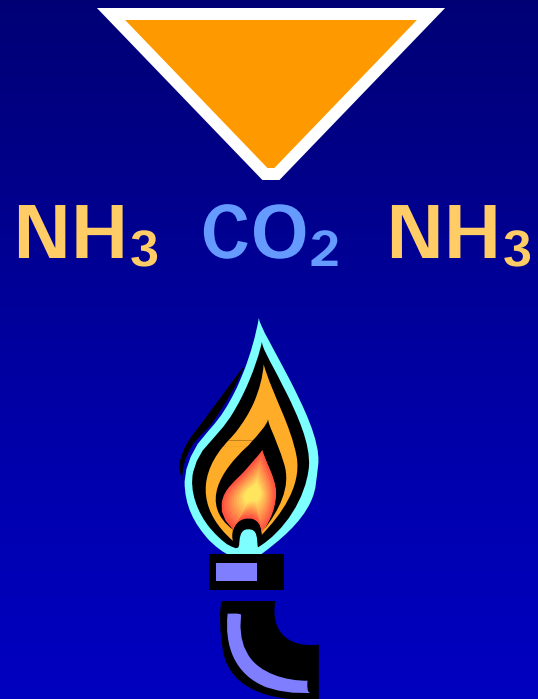

WAHLCO[®]

Copyright 2008, Wahlco, Inc.

U₂A[®]

www.wahlco.com

714-979-7300

Urea Production

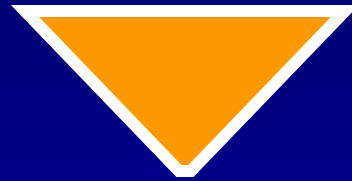

Ammonium Carbamate



WAHLCO[®]

Copyright 2008, Wahlco, Inc.

U₂A[®]

www.wahlco.com

714-979-7300

Urea Production

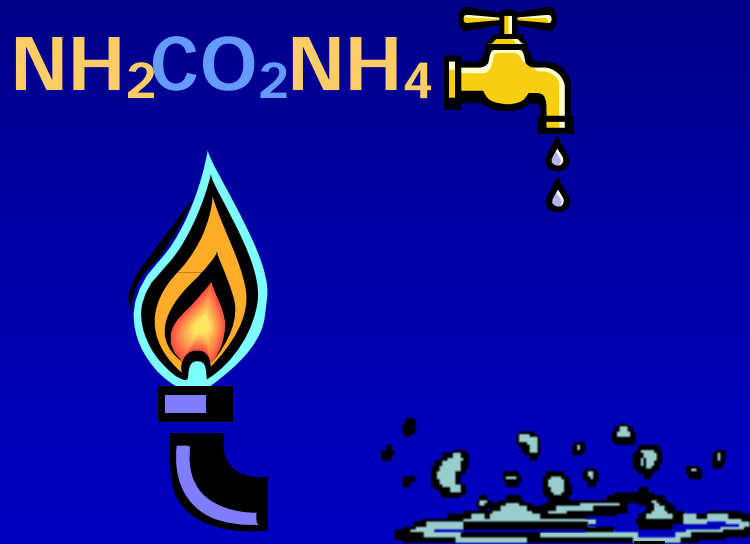

Ammonium Carbamate



WAHLCO[®]

Copyright 2008, Wahlco, Inc.

U₂A[®]

www.wahlco.com

714-979-7300

Urea Production



UREA



WAHLCO[®]

Copyright 2008, Wahlco, Inc.

U₂A[®]

www.wahlco.com

714-979-7300

Urea back to Ammonia



Urea back to Ammonia

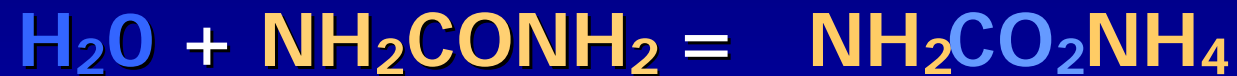

Ammonium Carbamate



WAHLCO[®]

Copyright 2008, Wahlco, Inc.

U₂A[®]

www.wahlco.com

714-979-7300

Urea back to Ammonia



Ammonia, Carbon Dioxide &
Water Vapor



WAHLCO[®]

Copyright 2008, Wahlco, Inc.

U₂A[®]

www.wahlco.com

714-979-7300

How does U₂A[®] work?

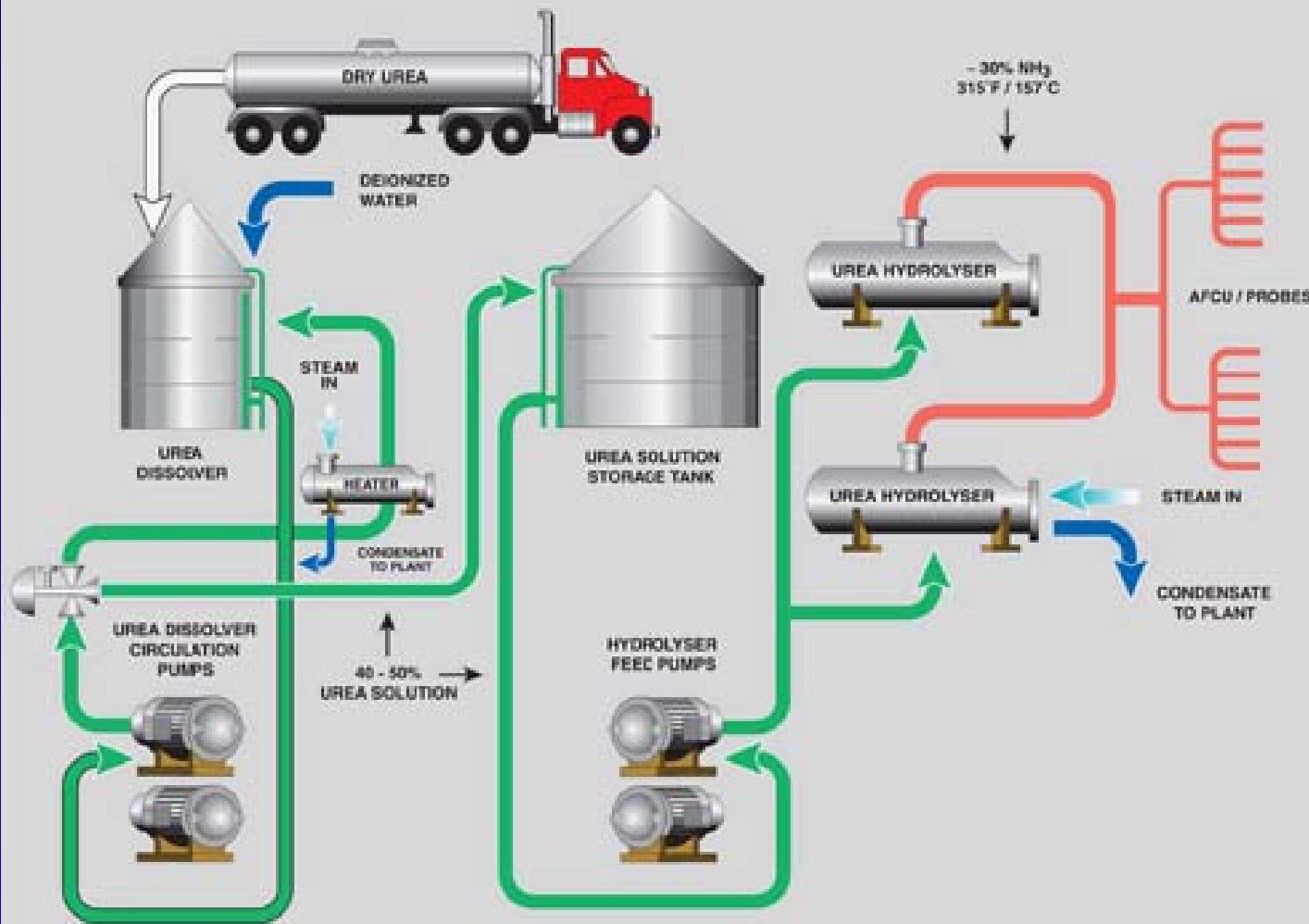

Dissolve Urea
(Urea + Water)



Hydrolyze
Urea Solution



Deliver
Product Gas
(on-demand)

Process Description

- Urea Hydrolysis
 - 40 to 50% Urea Pumped to Reactor
 - Heated to about 300°F
 - Pressure of 40 to 120 psig
 - 40% Decomposes to:
 - 28.5% Vol. Ammonia Vapor
 - 14.3% Vol. Carbon Dioxide
 - 57.2% Vol. Water Vapor



WAHLCO[®]

Copyright 2008, Wahlco, Inc.

U₂A[®]

www.wahlco.com

714-979-7300

Process Requirements

- Urea Hydrolysis
 - 1 lb NH₃ per 1.74 lb of Urea
 - For 40% Solution
 - Steam ~ 6 lb/ lb NH₃
 - 20% less Steam for 50% Solution
 - 40% Requires 2.65 lb Water per lb NH₃



Load Following Data

- Process easily follows boiler load variations
 - CPSG Wagner Station

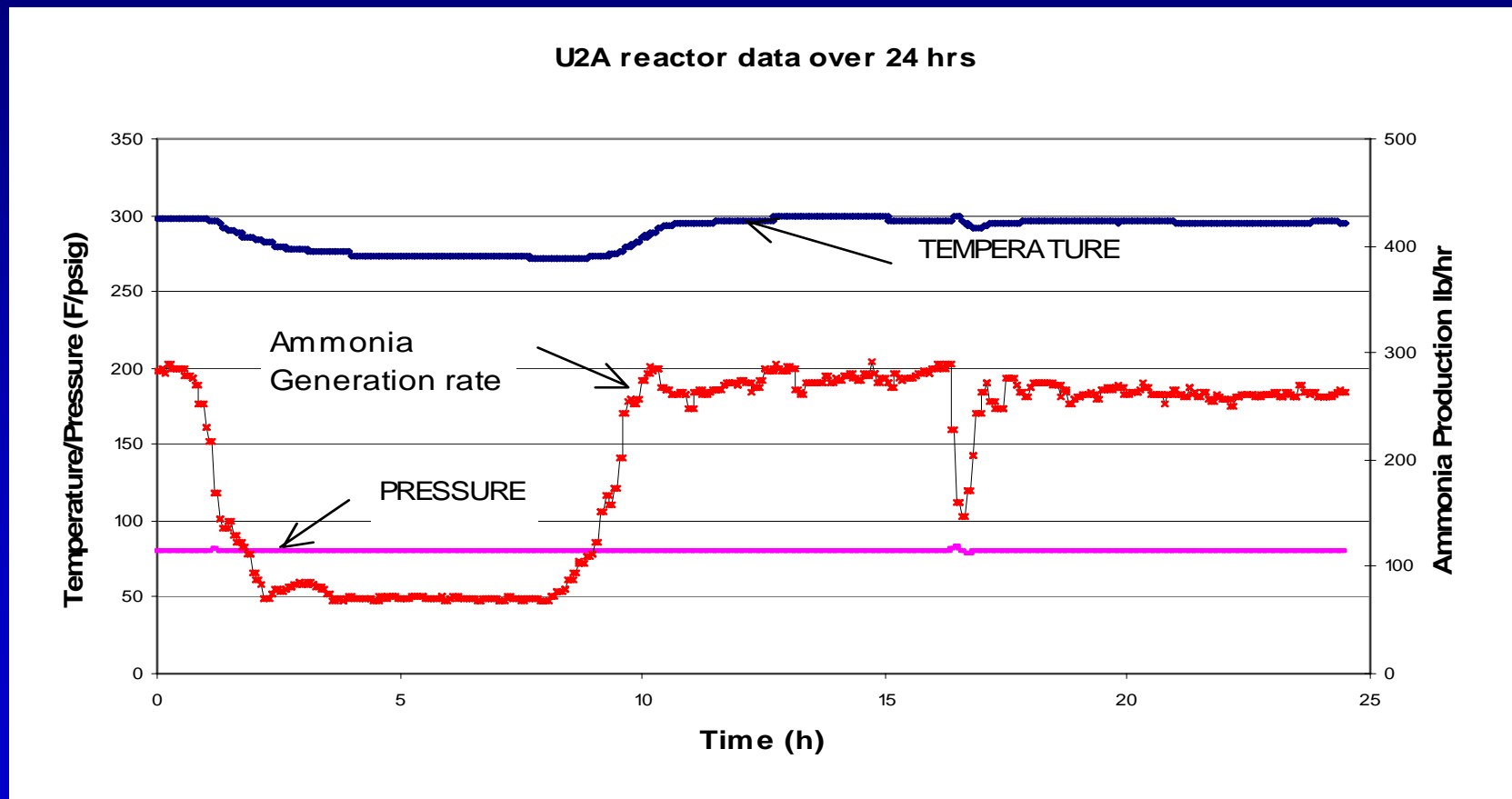

WAHLCO®

Copyright 2008, Wahlco, Inc.

U₂A®

www.wahlco.com

714-979-7300

Reactor Cross Section

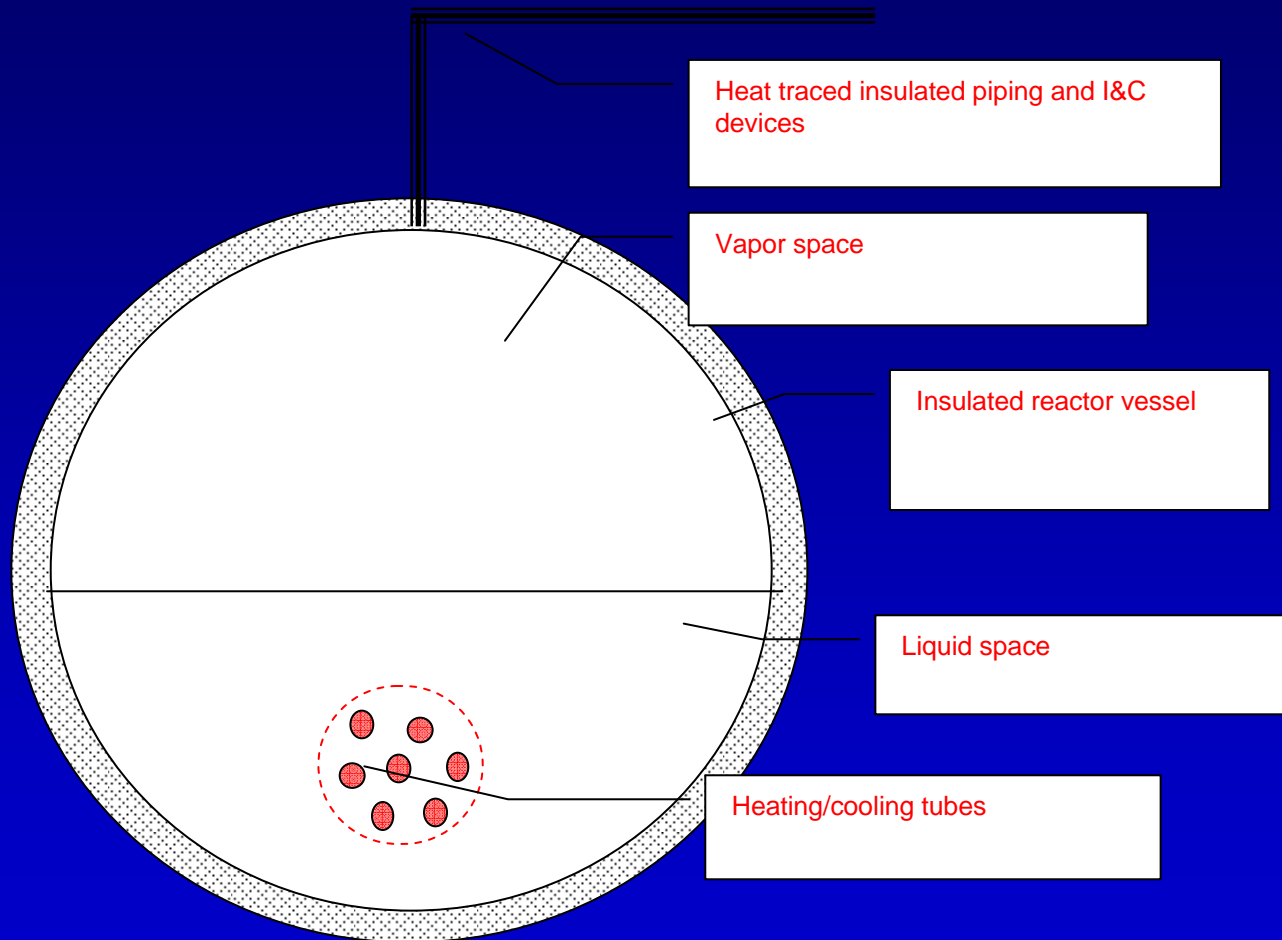

Mitchell Hydrolyser (3500 lb/hr. NH₃)



WAHLCO®

Copyright 2008, Wahlco, Inc.

U2A®

www.wahlco.com

714-979-7300

U₂A[®] Projects

– Crystal River	5,892 lb/hr
– AEP Mitchell Station Units 1 & 2	3,300 lb/hr
– Moneypoint Power Station	2,860 lb/hr
– Mirant Morgantown	2,650 lb/hr
– Constellation Brandon Shores Station	2,350 lb/hr
– Hitachi Seminole	2,176 lb/hr
– Allegheny Energy Pleasants Station	1,850 lb/hr
– AEP Conesville Station Unit 4	1,700 lb/hr
– Progress Energy Asheville	820 lb/hr
– Duke Marshall 3	610 lb/hr
– Mid American Council Bluffs	410 lb/hr



WAHLCO[®]

Copyright 2008, Wahlco, Inc.

U₂A[®]

www.wahlco.com

714-979-7300

U₂A[®] Projects (continued)

– Constellation Wagner Station	460 lb/hr
– AES Huntington Beach Station	380 lb/hr
– City of Spokane	300 lb/hr
– S & W Astoria	250 lb/hr
– AES Alamitos Station	240 lb/hr
– Namjeju Korea	160 lb/hr
– Termokimik AMSA	138 lb/hr
– White Mountain Energy	90 lb/hr
– Termokimik AMSA	33 lb/hr
– IST/(Dominion)/Kauai	28 lb/hr
– Protecma – Reggio Emilia	22 lb/hr
– UCLA	21 lb/hr
– Sinclair Oil	6 lb/hr



WAHLCO[®]

Copyright 2008, Wahlco, Inc.

U₂A[®]

www.wahlco.com

714-979-7300

Safety Issues with Ammonia Reagents



WAHLCO[®]

Copyright 2008, Wahlco, Inc.

U₂A[®]

www.wahlco.com

714-979-7300

Safety Issues

- Anhydrous Ammonia
 - Toxic Substance
 - Potential Combustion Issue
 - Hazard Risk During Transport, Storage, and Vaporizing
- Aqueous ammonia
 - Still Toxic (not as severe as anhydrous ammonia)
 - Increased Traffic Due to High Volume
 - Large Storage Volume at the Site
- Urea
 - Non Hazardous, Non Toxic, Inert Stable Material

Ammonia Effects

Effect	Ammonia ppm
Least perceptible odor	5 ppm
Readily detectable odor	20-50 ppm
No discomfort or impairment of health for prolonged exposure	50-100 ppm
General discomfort and eye-tearing; No lasting effect on short exposure	150-200 ppm
Severe irritation of eyes, ears, nose and throat; No lasting effect on short exposure	400-700 ppm
Coughing, bronchial spasms	1,700 ppm
Dangerous, less than ½ hour exposure may be fatal	2000-3000 ppm
Serious edema, strangulation, asphyxia, rapidly fatal	5000-10,000 ppm
Immediately fatal	>10,000 ppm



WAHLCO®

Copyright 2008, Wahlco, Inc.

U2A®

www.wahlco.com

714-979-7300

The reality of disaster . . .



From NTSB – Pipeline Accident Brief

Accident No.: DCA05-MP001

Date: October 27, 2004

Material Released: Anhydrous Ammonia

Location: 6 miles west of Kingman, Kansas

- Ammonia pipeline accident near Kingman, Kansas (population 3,387 as of 2000)
- 204,000 gallons released
- Ammonia aerosol cloud formed that traveled close to the ground
- **Severe Hazard** – one breath of aerosol cloud vapor would have been immediately fatal



WAHLCO[®]

Copyright 2008, Wahlco, Inc.

U2A[®]

www.wahlco.com

714-979-7300

EPA RMP Comp

14 Day Storage for 4 units each 612 lb/hr

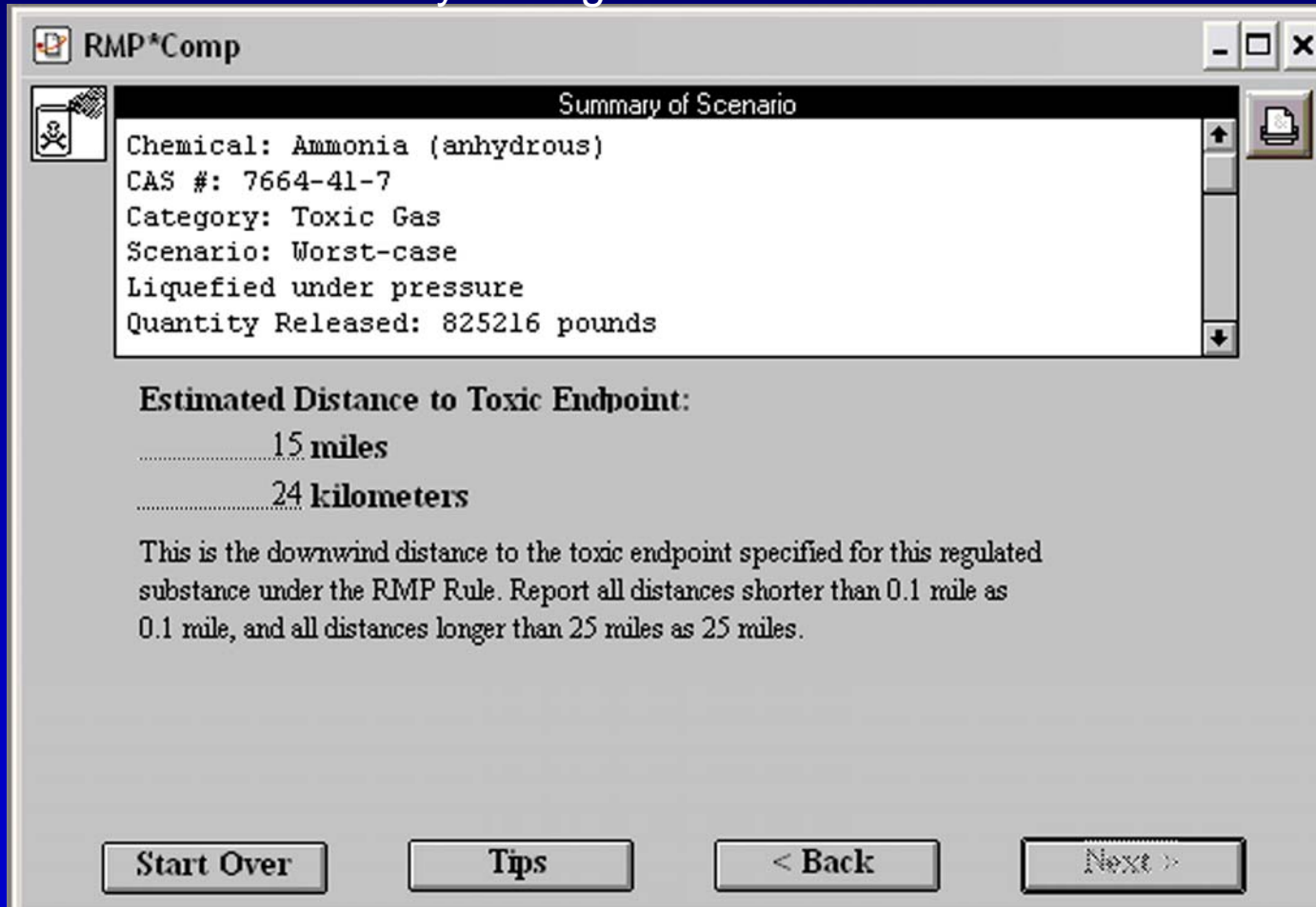

The screenshot shows a software window titled "RMP*Comp" with a "Summary of Scenario" section. The summary includes the following information:

- Chemical: Ammonia (anhydrous)
- CAS #: 7664-41-7
- Category: Toxic Gas
- Scenario: Worst-case
- Liquefied under pressure
- Quantity Released: 825216 pounds

Below the summary, the "Estimated Distance to Toxic Endpoint:" is displayed as:

-15 miles
-24 kilometers

A note below the distances states: "This is the downwind distance to the toxic endpoint specified for this regulated substance under the RMP Rule. Report all distances shorter than 0.1 mile as 0.1 mile, and all distances longer than 25 miles as 25 miles."

At the bottom of the window, there are four buttons: "Start Over", "Tips", "< Back", and "Next >".

Toxic End Pts for NH3 Spills

Storage of
204,304 lbs
612 lbs/hr for
14 day

RMP Comp Worst Case

1 Truck Load
50,000 lbs

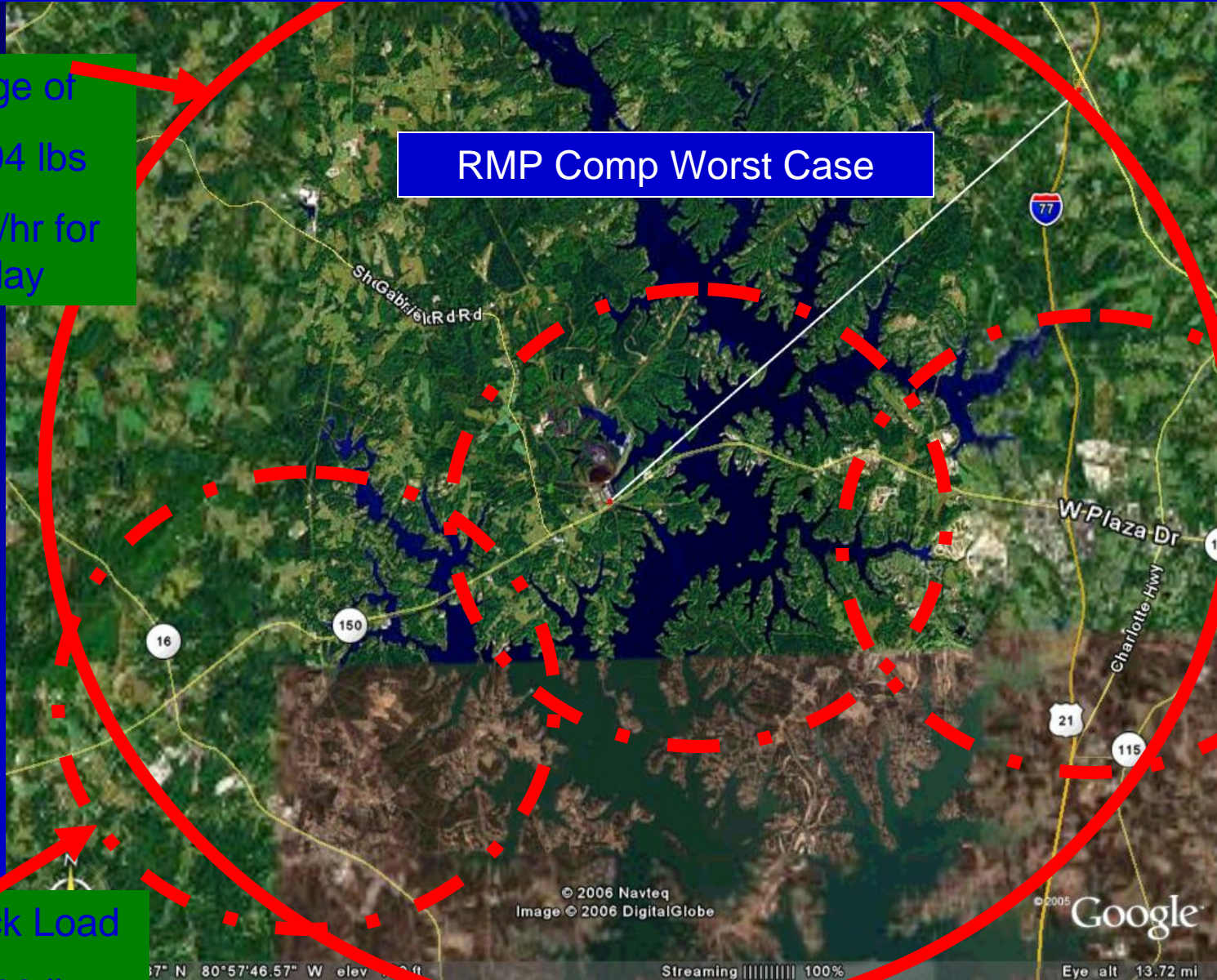

© 2006 Navteq
Image © 2006 DigitalGlobe

© 2005 Google

37° N 80° 57' 46.57" W elev 20 ft

Streaming | 100%

Eye alt 13.72 mi

Storage Volume Issues

- Anhydrous Ammonia
 - Lower than Aqueous Ammonia or Urea Based System
- Aqueous ammonia
 - High (25 % ammonia; 75 % water)
 - For example: 1 kg of 25 % solution produces 0.25 kg of NH₃
- Urea
 - Delivered dry as prill/granular
 - 1 kg of Urea produces 0.56 kg of NH₃
 - Dissolved at Site Producing 40 to 50% solution (plant DI water)
 - Stored as Solution (storage tank volume similar to aqua ammonia)

Storage Comparisons

Based upon NH₃ Demand

445 lb/hr

	Anhydrous	19% Aqueous	50% Urea Solution
10 Day Storage Pounds	106,800	562,105	381,429
10 Day Storage Gallons	21,360	72,812	40,363
Number of Trucks per week	2	10	3
Toxic Endpoint per EPA RMP	5.6 Mile Radius	4.7 Mile Radius	N/A

AMMONIA REAGENT COST COMPARISONS



WAHLCO®

Copyright 2008, Wahlco, Inc.

U₂A®

www.wahlco.com

714-979-7300

Urea vs. Ammonia - chemical cost

– Ammonia and urea track with natural gas prices

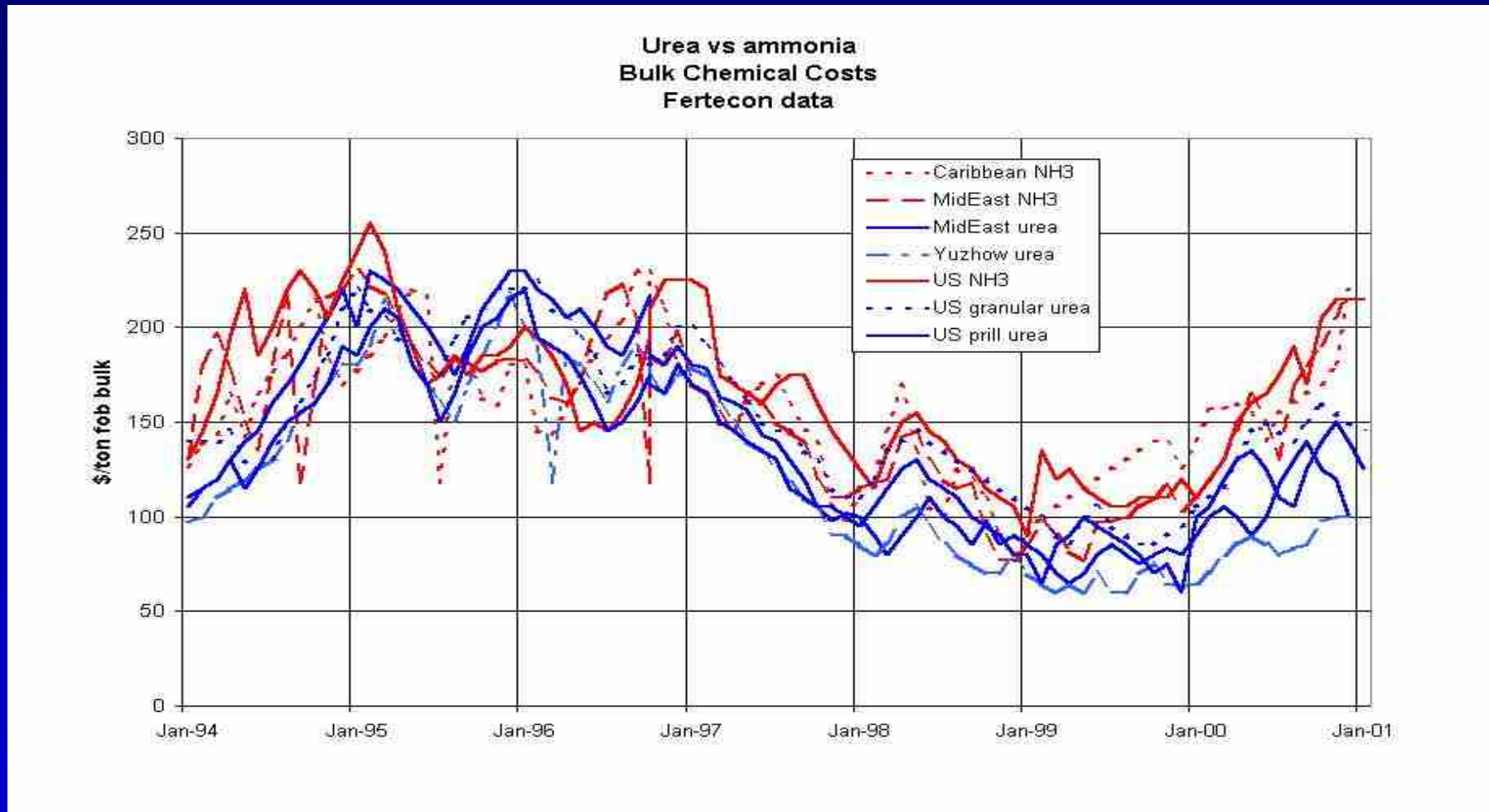

Anhydrous-Aqueous-Urea Price Trends

Urea - Ammonia Price Trends

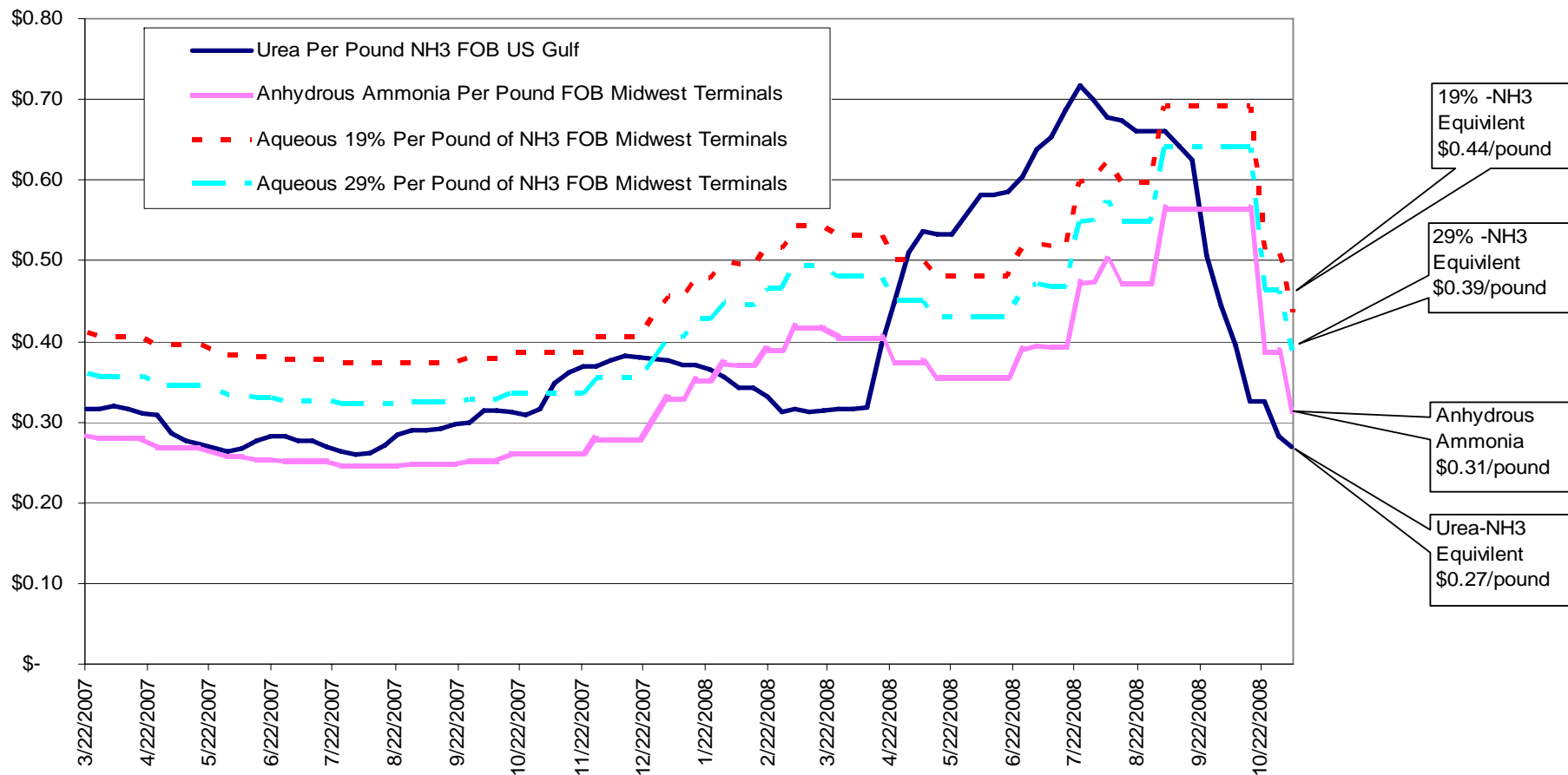

Koch Ammonia Prices

- Delivered Central Illinois
- Quoted 7/15/08
- NH₃ ~ \$1140 ton (\$800 ton Tampa)
- Urea ~ \$750 ton (\$1320 ton NH₃)
- 29% Aqueous ~ \$371 ton (\$1280 ton NH₃)
- 19% Aqueous ~ \$263 ton (\$1380 ton NH₃)
 - Recent Boston 19% ~ \$280 ton (\$1474 ton NH₃)
- Transportation Costs much more for Anhydrous

Reagent System Cost Comparison

- Budgetary Costs for Capital Equipment
 - Nominal 1,600 lb per hour ammonia
 - 15 day chemical storage capacity
 - 100% equipment redundancy
 - 2 x 100% hydrolysers serving 2 boilers
- Anhydrous Ammonia: \$2.5-\$2.8 million
- Aqueous Ammonia: \$3.2-\$3.5 million
- U2A \$4.5-\$5.5 million

Utility Consumption for SCR Applications

- Anhydrous Ammonia Vaporization
 - 540 btu's per lb of ammonia (0.16 kW)
 - AFCU ~ .32 kW lb NH₃
- Aqueous Ammonia (19%) Vaporization
 - 7750 btu's/lb of ammonia (2.3 kW)
 - AFCU ~ .70 kW lb NH₃
 - (5.26 lb water / lb ammonia)
- Urea to Ammonia -50% Urea
 - 3354 btu's/lb ammonia (0.98 kW)
 - AFCU ~ .28 kW lb NH₃
 - (1.76 lb water / lb ammonia)

Yearly Operating Cost

Feed stock costs based on average of first 9 months of 2008

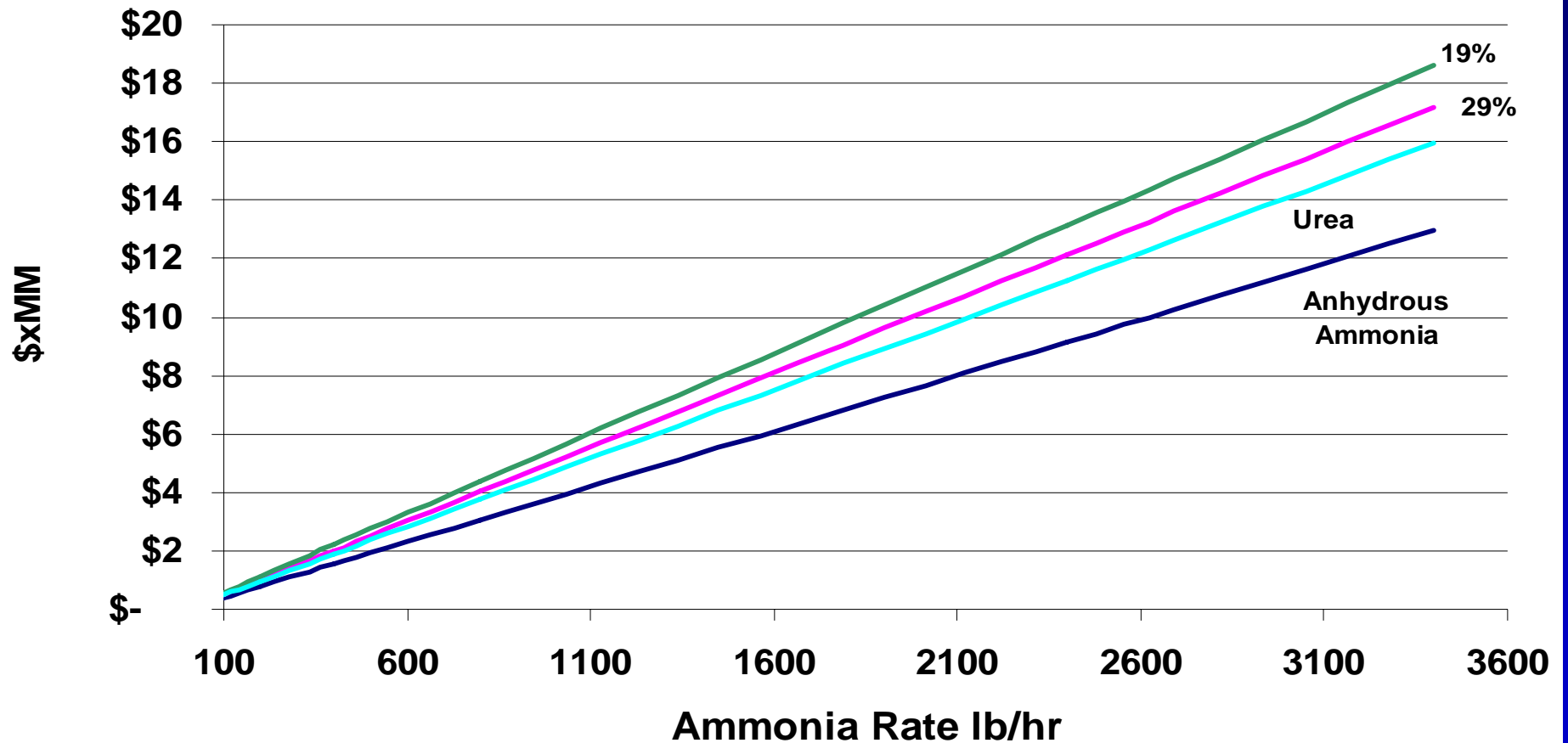

Technology Comparison Summary

- Anhydrous

- Highest Risk



Lowest Cost



- 19% Aqueous

- Calculated Risk



Highest Overall Cost



- Urea to Ammonia

- Lowest Risk



Moderate Cost



Questions

Tim Leach

714-338-3669

tleach@wahlco.com



WAHLCO[®]

Copyright 2008, Wahlco, Inc.

U2A[®]

www.wahlco.com

714-979-7300